

Model

**B
P
+**

PROTA™CULTURE

Harvesting Waste Naturally

**BioPod™ Plus
Grub Composter
Manual & User's Guide**

BioPod™ Plus - User's Guide



© 2010 – All Rights Reserved. Last revision February 2012

Prota™ Culture
PO Box 660675 #15135
Dallas, Texas 75266-0675
Phone 214-509-6000
Facsimile 214-279-0445
CS@THEBIPOD.COM

Table of Contents

CHAPTER 1

Introduction page 2

CHAPTER 2

Parts page 6

CHAPTER 3

Assembly page 9

CHAPTER 4

Set Up Tips page 12

CHAPTER 5

Operations page 16

CHAPTER 6

Troubleshooting page 20

CHAPTER 7

Projects For Kids page 27

CHAPTER 8

Glossary page 29

CHAPTER 9

Acknowledgements page 31

CHAPTER 10

Contact Info page 32

Introduction

The future of residential food waste recycling

Thank you for purchasing the residential BioPod™ Plus – the next generation of bioconversion units developed by Prota™ Culture. This unit is the culmination of 9+ years of collaborative research with dozens of experts on four different continents.

Never before has there existed a sustainable technology that is so quick and efficient at biologically converting kitchen waste and/or fresh manure into useful and valuable end products. The primary decomposer in the BioPod™ Plus is the juvenile form of the harmless and beneficial **black soldier fly** (*Hermetia illucens*) – a species native to Southeastern North America but naturalized in many regions of the globe. Black soldier fly (“BSF”) adults do NOT bite, sting, create a nuisance, or transmit disease. In fact their very presence inhibits the growth of filth flies, like the common housefly.

Whatever your goal may be – whether it’s to lower your impact on the Earth or become more self-reliant - we sincerely hope your experience with the BioPod™ Plus is both rewarding and positive. All that we ask in return is that you share what you have learned with others, so that they may benefit by setting up their own sustainable food waste recycling systems.

How to Use This Manual

Anytime you see **BOLD TEXT** in this manual, it means we are trying to emphasize the point. Please re-read the sentence – it means the topic is important and worth remembering.

You may mark up and reference this guide as needed. At the back of this manual in the GLOSSARY section is a list of definitions, in case some of the terminology is unfamiliar. Please review at your convenience. **Keep this guide in a safe place so that you have it for future reference.** In the event this document becomes worn or soiled, the latest version may be downloaded via the internet from the customer service section of our website. For the latest tips, advice and updates, please visit the **FORUM** section of our website: www.TheBioPod.com.

Eco-Benefits of the BioPod™ Plus

Enlightened consumers have come to realize that recycling waste is part of being an environmentally conscious citizen. Traditionally, it has been difficult to find a quick and convenient way to dispose of food scraps, other than throwing them in the garbage (1) or down the insinkerator (2). Food leftovers are the single largest component of the solid waste stream by

weight in the US (equates to 12% of the municipal solid waste). In fact, we throw away 25% of the food we prepare, which is approximately 96 billion lbs of food scraps annually. As a nation we spend about 1 billion dollars just to dispose of this uneaten, wasted food. Only 3-4% of this is currently recovered – the vast majority goes to landfills or is combusted at incineration plants.

E C O B E N E F I T S	
👉	recycle all food scraps
👉	saves landfill space
👉	reduce strain on sewers
👉	reduce greenhouse gases
👉	saves energy
👉	creates liquid fertilizer
👉	nutritious soil amendment
👉	food source for redworms

The anaerobic decomposition (decay without oxygen present) of food waste in our dumps produces **methane**, a potent greenhouse gas 20+ times more powerful than carbon dioxide. Incidentally, landfills are the single largest human source of methane in the US.

Unfortunately, in-sink garbage disposers are not an ideal solution either. Studies suggest that this disposal method can adversely impact the waste treatment facility with too many unnecessary bio-solids, and affect riparian ecosystems downstream by introducing an excess of water-borne nutrients into the watershed. This may result in algae blooms and potentially deadly eutrophication of the water bodies – affecting wildlife and fisheries.

When examining comprehensive life cycle assessments of waste, and taking into account comparative research studies, researchers conclude that *home composting systems had the smallest ecological impact across all environmental categories*, including energy consumption.

Diversion of Food Waste by Recycling. Reusing food through donations or by recycling using the BioPod™ Plus prevents its entry into dumps or incinerators, thus reducing greenhouse gas emissions. Over the long term, diverting any kind of waste from the landfill and implementation of source reduction strategies saves money by lowering disposal, collection and tipping fees.

Throwing your food waste into the garbage is a messy, smelly chore and can potentially contaminate your recyclables. Almost immediately, bagged refuse starts to breakdown anaerobically, producing offensive odors and unsanitary conditions, while potentially attracting unwanted animals. A better strategy is to keep your food scraps out of your garbage and recycle all of them aerobically in the BioPod™ Plus.

Occasionally, subsidies and rebates are available through your local municipality to offset the purchase price of a composting system like the BioPod™ Plus. **Please consult the solid waste division of your city’s public works department, your local water treatment authority or your trash hauler for details on local subsidy programs.**

Beneficial End Products

Balanced, living soils are one of the key ingredients to a vibrant, healthy backyard garden. Like other home composters and food recycling units, the BioPod™ Plus produces biologically active compost referred to as **Grub Castings**. However, what sets our system apart from other models is the speed at which digestion occurs. Instead of waiting 6-12 months to begin generating finished compost, you can have garden-ready grub castings in only a few weeks. Though **relatively small in quantity**, this black-colored, friable material has the texture of dry, coffee grounds and is nutritious enough to be added directly to your potted plants and raised garden beds. **Grub castings and undigested residue is an excellent worm food and may be further enhanced by using redworms to fully process into valuable vermiculture castings.** For

every 100 lbs of food scraps added to the pod, approx. **5 lbs** of grub castings are created (20:1 ratio).

The concentrated liquid effluent or ‘**Grub Leachate**’ that seeps passively into the liquid catchment section contains many trace elements and beneficial bacteria, and may be used as a soluble, ornamental plant fertilizer, provided it is diluted with non-chlorinated water or rain water. **This liquid may also be used as a powerful attractant of adult females to newly setup grub composters. Due to the acidic nature of the effluent and its high bacteria count, always wear protective glasses and gloves when handling.**

Soldier Grubs - the highly versatile and nutritious BSF prepupae are the coveted end product of the BioPod™ Plus. These beneficial larvae have a myriad of uses, and contain approx. 42% protein and 34% lipids (fat), with an impressive amino acid and mineral profile. Soldier grubs are so user-friendly, they can be gathered and dispensed by a child's hand - they do not transmit harmful pathogens, stain clothes, or possess sharp barbs. During auto crawl off, the mature prepupae naturally cleanse their entire GI tract, so they are not going to poop while in your hand. They are normally dry to the touch when harvested out of the collection bucket, and do not have an offensive odor. If you start producing more soldier grubs than your animals or hobby can consume, simply rinse off and freeze the extra – then use at your convenience. Always remember to allow some of the mature grubs to pupate and hatch out into adults so that the local population is sustained and magnified. Because food scraps can harbor nasty germs, always wash your hands after handling grubs that were raised on food waste. You may also rinse the grubs before using – this practice will not harm them whatsoever.

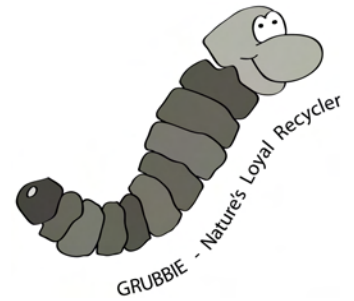

- 1. Nutritious Songbird Feed.** Soldier grubs are an ideal food for attracting *bluebirds, orioles, cardinals, goldfinches, thrushes, catbirds, woodpeckers, nuthatchers, chickadees, mockingbirds and warblers* – to name a few. The logical and most common means of offering the grubs is to use a special bluebird feeder, or similar unit that has been designed to distribute mealworms to birds. Look for units that possess a sloped, overhanging lid or roof that will prevent runoff of rain or dew into the feeding area. Drainage holes and critter guards are also beneficial to a functional feeder.
- 2. Ornamental Fishpond / Aquarium Feed.** High in usable protein and low in ash. Your goldfish, koi, large cichlids and other pond creatures will relish the live, fresh grubs that are simple to dispense in a tank or backyard pond.
- 3. Live Fishing Bait.** Our home-grown soldier grubs are easy to store, simple to transport and a pleasure to bait on a hook – their durable bodies don't fall apart or get easily ripped up by hungry fish, unlike earthworms or bread balls. Why dig up your sod and vegetable garden looking for worms when you can have a constant supply of tasty, auto-harvesting soldier grubs.
- 4. Raising Chickens.** Did you know that a healthy hen fed a balanced diet can lay fresh, wholesome eggs for up to 18 years? It is rewarding and a lot of fun to have a small hobby farm in the backyard. A homemade movable coop that confines and shelters your small flock is easy to build and takes up a lot less space than you may

realize. Chickens love to scratch the dirt endlessly looking for tasty grubs and other insects. A few handfuls a day of soldier grubs scattered throughout the garden will provide hours of enjoyment for your friends and family. There is a multitude of excellent poultry rearing websites online that will give advice on coop construction and care. Please research the topic thoroughly before you begin. Just keep in mind that the structure should be well ventilated, secure from predators, have a built-in shaded area and provide a minimum of 3 square feet of space per bird. A constant supply of fresh water fortified with vitamins and probiotics, along with a balanced diet that includes soldier grubs, will help to produce a happy, healthy, egg-laying flock. Please consult your local ordinances as they pertain to residential restrictions on bird rearing and poultry.

The **'Golden Rule'** of a balanced chicken diet: **1/3 greens, 1/3 grains and 1/3 insects**. Based on a daily consumption of 1/3 lb of food per day per adult chicken, the feed estimates would be 1/9 lb greens, 1/9 lb grains and 1/9 lb insects. If your pod is eating 3 lbs of food scraps per day and you have a bioconversion rate of 17%, your pod is producing approx. 1/2 lb of grubs per day. That is enough insect matter in a balanced diet for 3 adult chickens, based on the golden rule above. Please keep in mind these figures can vary widely based on local conditions, breed and scrap type.

Lbs of Feed / Day / Chicken	# of Grubs / Day (1/3 of diet)	Food Scraps Eaten / Day / BioPod Plus			Conversion Rate (of mixed food scraps)	# of Supported Chickens		
		3 lb	4 lb	5 lb				
.5 lbs	.16 lb	3 lb	4 lb	5 lb	17% (ranges from 15-20%)	3	4	5
.33 lb	.11 lb	3 lb	4 lb	5 lb	17%	4.5	6	8
.25 lb	.08 lb	3 lb	4 lb	5 lb	17%	6	8.5	10.5
.20 lb	.06 lb	3 lb	4 lb	5 lb	17%	8.5	11	14

5. Freshwater Aquaculture or Aquaponics. Raising domesticated freshwater bass, catfish, shrimp or tilapia in a small pond or converted pool is a cost-effective and sustainable means of supplying you family with a healthy, year-round protein source. Live, frozen or dried soldier grubs may be fed directly to your stock, reducing demand for commercial grade feed. If you have limited space, all-inclusive integrated aquaponic systems can be purchased online, giving your family access to fresh herbs and salad greens as well as chemical-free fish. Please visit www.aquaponics.com for more information on starter kits. Before you begin, please research local restrictions on non-native fish breeding.

6. Reptiles and Amphibians. There are many species that will relish BSF – the grubs not only provide essential nutrients like calcium, they help entice finicky eaters with their slow undulating wiggle. An ideal food if you are going to raise bullfrogs for food or pleasure!

7. Pigs. BSF grubs are a wonderful dietary supplement and an excellent source of protein for pigs.

List of Parts

Please check the contents of your box before assembly



Check Parts First

Before you proceed to the next chapter, please check to see that you have all the parts necessary for proper assembly. Please use the illustrated list below as your guide. There should only be one of each plastic part in your box.

Extra Parts

Should you need or want extra parts for your BioPod™ Plus please visit our website for instructions on how to order replacement parts..

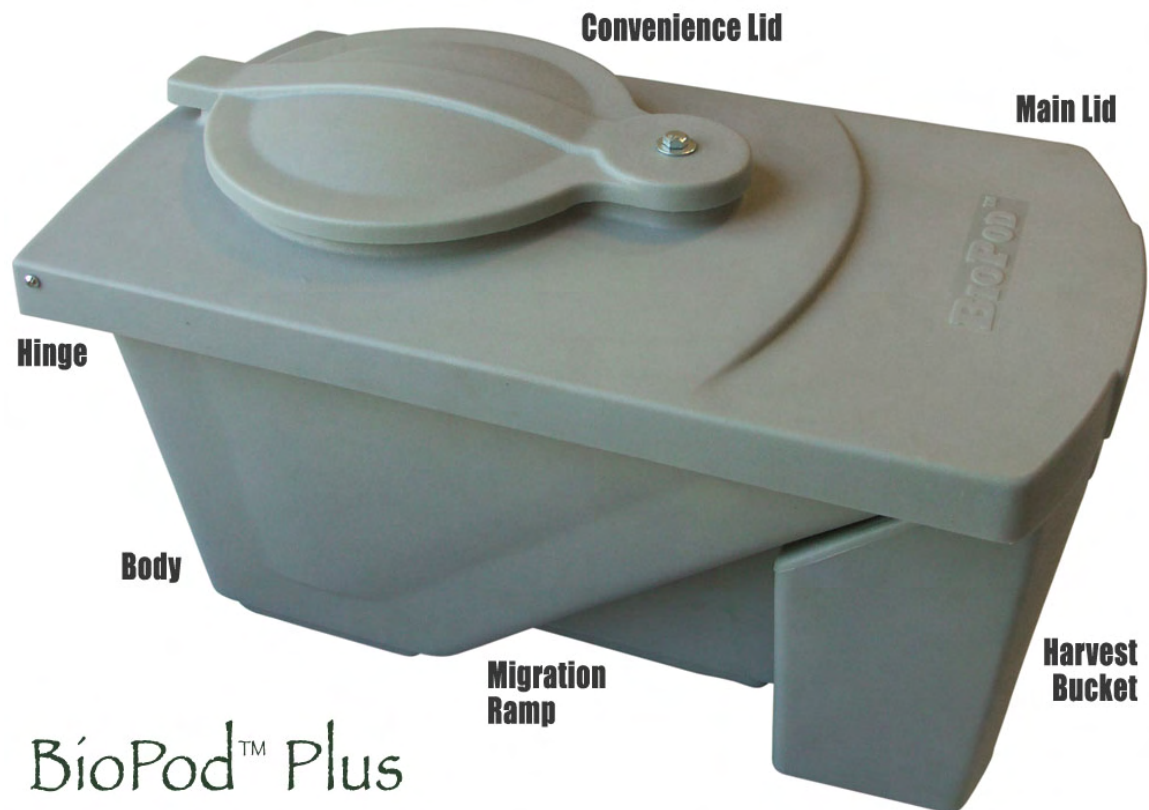

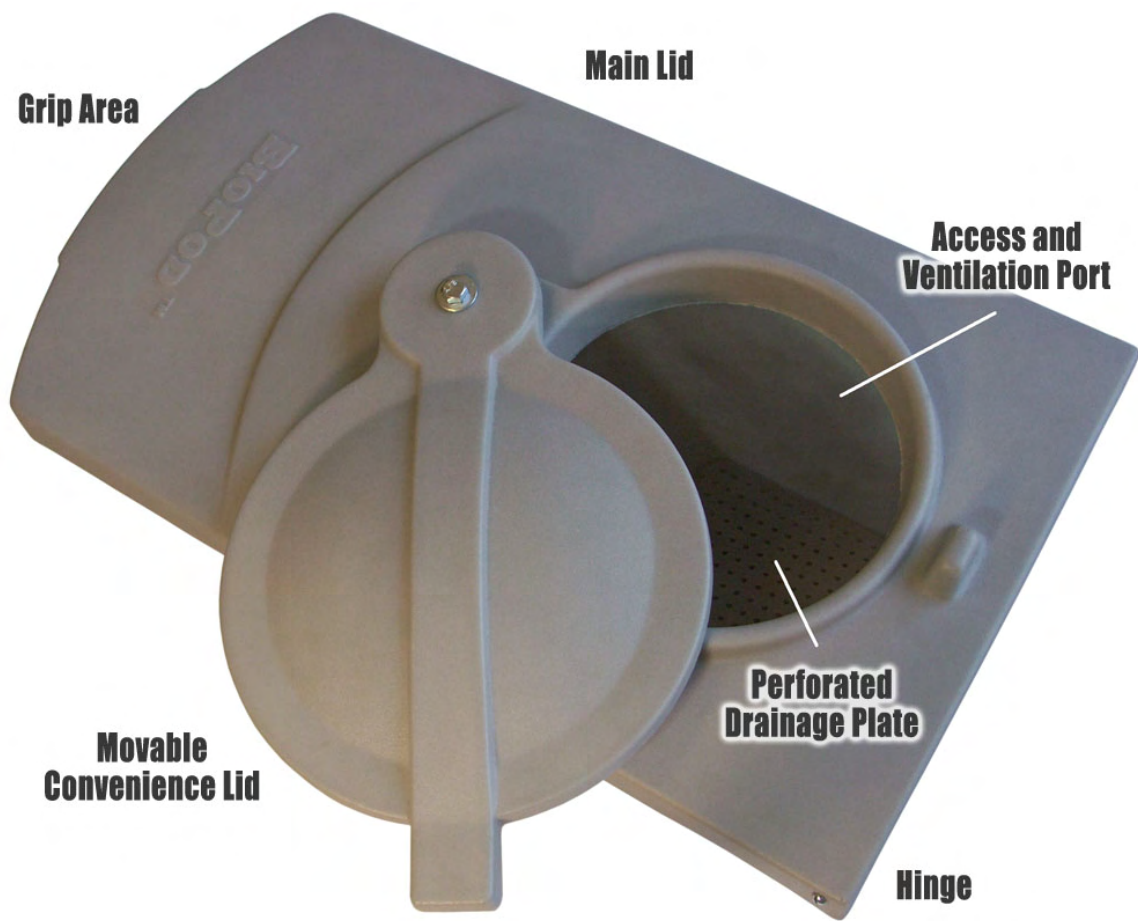

Included Parts List

1. MAIN BODY
2. MAIN LID
3. INNER CONVENIENCE LID
4. INNER LID HARDWARE *
 - A. BOLT (1)
 - B. NUT (1)
 - C. WASHERS (2)
5. HINGE HARDWARE FOR MAIN LID *
 - A. BOLT (2)
 - B. NUT (2)
 - C. WASHERS (4)
6. PERFORATED DRAINAGE PLATE
7. DRAINAGE PAD
8. COLLECTION / HARVEST BUCKET
9. DRAINAGE HARDWARE
 - A. SMALL PLASTIC HEX CONNECTOR
 - B. LARGE PLASTIC HEX CONNECTOR
 - C. CLEAR TUBE
 - D. RESTRICTOR (models before May 2011)
 - E. PINCH VALVE (models after May 2011)
 - F. END CAP

Drainage Plate



Drainage Pad



Drainage Assembly (see p. 10 for more details)

* Please note that all bolts, nuts and washers are the same size

Assembly

Please use the step by step instructions as your guide

- **STEP 1 – LOCATION / PLACEMENT**

Pick an outdoor spot that has a **level surface** and is located in **full shade**. Do not situate the unit on a steep slope or angled surface – this may result in tipping. A 1-2% grade declination in the direction of the external, bottom port will assist with drainage.

To avoid the potential for tipping, make certain the final location is stable and as close to the horizontal as possible.

To avoid possible damage, do not position the unit too close to play areas. If full shade is not available, place in part-shade with a shade tarp so that the radiant heat from the sun doesn't produce excessive temperatures inside. Make every effort to avoid placement near electrical devices (air conditioners, pool filters) or radiant, thermal masses like concrete walls that may heat up the unit – try to keep internal temperatures below 100-105°F so that the pod continues to perform optimally and within acceptable parameters. A color changing, temperature sensitive flat thermometer with a sticky back placed on the lower section of the body is highly effective at monitoring the internal conditions. Elevating the unit on a small table allows for easier harvesting of grubs and liquid. For those individuals who chose not to collect the effluent, the unit must be situated on or over permeable ground that will allow natural drainage to occur continually (soil, sand, mulch, decomposed granite, gravel, wood chips, pine needles, live or dead grass, etc.). Non-porous surfaces like concrete or asphalt are not recommended for systems that naturally drain into the ground, resulting in pooling of the liquids. Please note: the effluent can be acidic and may stain surfaces.

- **STEP 2 - LID ASSEMBLY & ATTACHMENT**

If not already assembled, secure the bolt, washer 1, inner lid, main lid, washer 2, and nut, using the orientation and order as illustrated in the schematic to the right. Please note the hardware is not to scale. The underside of the inner convenience lid will serve as the entry point for egg laying females, as well as the ventilation port necessary for aeration and heat dissipation. The underside of the outer (or main) lid will be the location of the corrugated paper or plastic strips that can be optionally added – this will provide shelter for the newly laid eggs

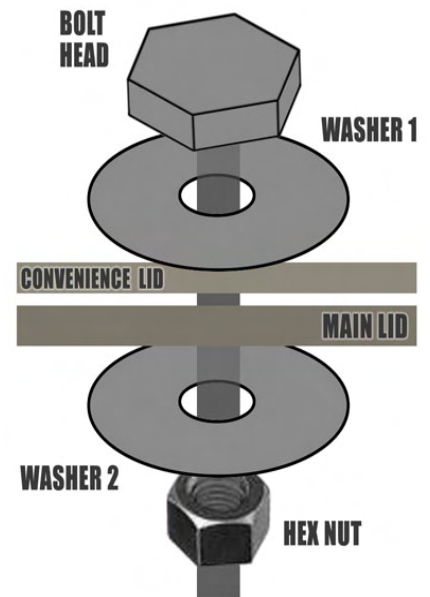

and protect them from predation by small animals such as lizards (see page 15, bottom-right for instructions on making your own egg laying strips). The completed lid assembly will cover the entire body of the pod, protecting the unit from precipitation, predation, bright light and debris. Place the lid assembly on the pod and flip the whole unit upside down. Using the nut bolt and washer combination, thread the bolt with attached washer through the hole in the lid and then the body (from the outside in) and secure with a second washer and nut. Repeat on the other side. Tighten just enough so the lid will stay open without having to hold it. Check occasionally and tighten accordingly.

- **STEP 3 - DRAINAGE ASSEMBLY**

Before attaching the assembled lid to the unit, become familiar with the area where liquids will be stored, until such time as you drain the reservoir. Note the rounded edge and bump supports as well as the exit port. Once you understand where the compost leachate is to be contained, place the perforated drainage base plate on top of the liquid catchment area (both sides are the same). Next, place the green drainage pad **on top of** the rigid base plate. This will assist with drainage and help maintain the proper aerobic conditions. Moreover, This will effectively prevent newborn babies and coarse particulates from fall into the liquid catchment area. Adults will invariably find their way into the bottom compartment in their constant quest for food – do not worry – they can easily vacate along the periphery and will not easily drown. This drainage pad will not decompose and may be cleaned for reuse year after year. Grubs will bore in and through the drainage pad searching for food and shelter – they will not get trapped in the matrix. If you should need more drainage pad in the future, we have extra pads available for a nominal fee, or you can make your own out of air condition pads from home improvement stores.

Using a socket and wrench of compatible size, carefully thread the small plastic hex connector into the pod body. Do not overly tighten – **this piece is not meant to screw in all the way**. Before attaching the clear tube to the protruding end of the small connector, slide the restrictor over the tube and funnel the tube into the slit section – it should remain in this fully pinched position until such time as you wish to drain the liquid. Attach the other end of the tube to the larger plastic connector and twist on the cap. This double level of protection will help prevent your pod from dripping. If clogging does occur, simply remove the clear tube and excavate the small hex connector with a small twig or branch.

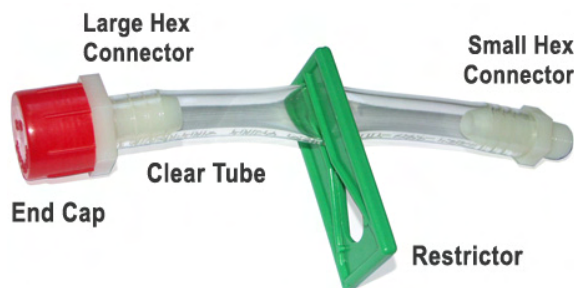

External Drainage Assembly
Pre-May 2011

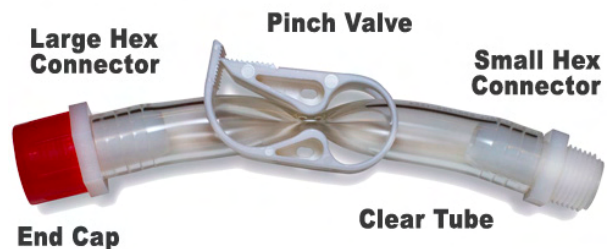

External Drainage Assembly
May 2011 Onward

- **STEP 4 – COLLECTION BUCKET**

Fill the bottom of the **collection bucket** with some slightly moist coir fiber (recycled coconut husks), sphagnum peat moss, sawdust, or unprocessed rice hulls. This will provide suitable bedding for the grubs as they begin to settle down in their new home and break their fall as they drop into the bucket. Overly wet conditions inside the harvest bucket allow the grubs to crawl up the sides – do not over moisten the bedding. Rainfall and precipitation will be shunted away from the inside of the bucket by a small indented groove around the edge of the top opening. The bottom of the collection bucket should be approximately at the same elevation as the bottom of the unit’s body. The top of the bucket fits nicely underneath the front part of the main lid; the downward pressure of the lid will keep the collection bucket in place as it begins to fill with grubs. Use the handle to grab the bucket for removal or carrying around. Do not block the opening on the collection bucket as this doubles as an air intake port, helping to maintain aerobic conditions and providing the grubs with oxygen. Don’t use the collection bucket to store grubs for more than a few days – empty as needed.

- **STEP 5 – OPTIONAL FASTENERS**

To prevent the lid from being carried off by the wind or opened by hungry critters or curious children, use a standard spider bungee cord to hold the lid and harvest bucket securely in place.

Bucket Bedding

This should be a slightly moist, non-toxic, and non-caustic material. Excellent choices include rice hulls, peat, coir, saw dust and coir fibers. If none of these are available, you may substitute dry shredded office paper.

FULLY ASSEMBLED BIOPOD PLUS SYSTEM

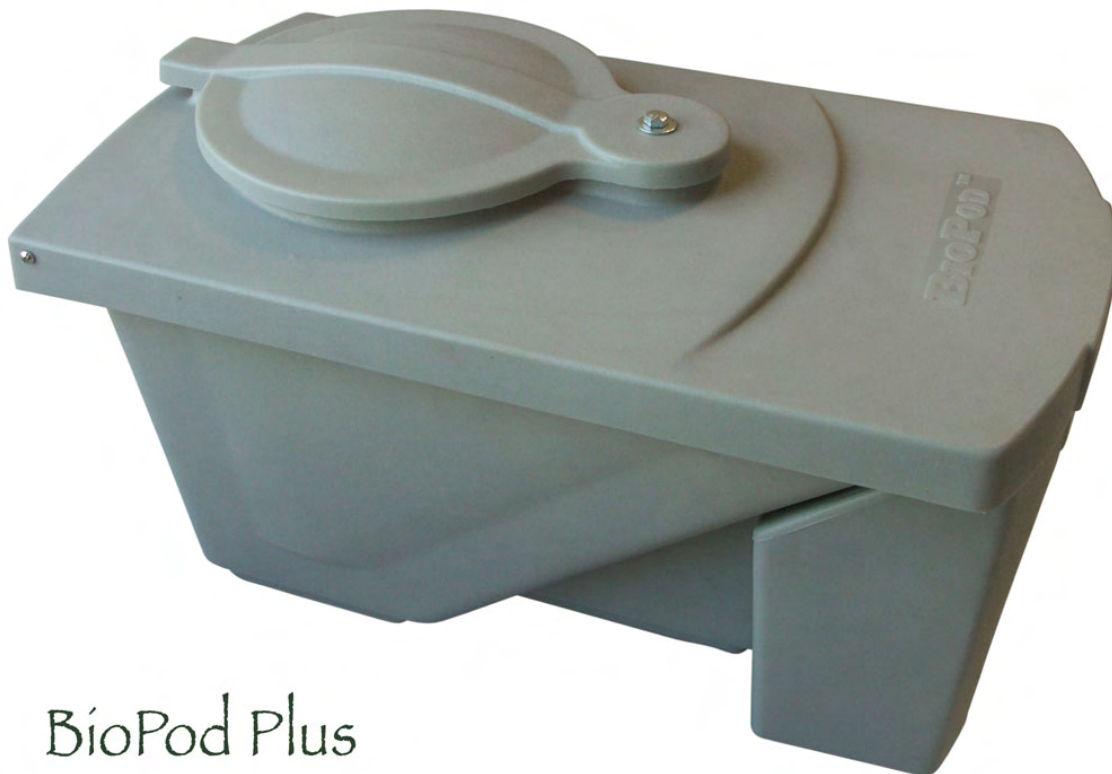

BioPod Plus

Set Up Instructions

Some recommendations as you set up your unit

BEFORE U BEGIN

1. FIND SHADE
2. FLAT SURFACE
3. NO BEDDING

Shady Location Required. Like worm bins, Prota™ Culture systems like the BioPod™ Plus operate best in **full shade conditions**. Though BSF can handle higher heat intensities than redworms, they can suffer when ambient temperatures exceed 100-105° F for more than a few hours. We highly recommend providing as much shade as possible using a shade cloth or tarp when a full shade location is not available.

Find a Level Surface. Place the BioPod™ Plus in an area that is flat and horizontal (a slight 1-2° tilt toward the drainage port is helpful). If your entire property is on a slope, provide ample leveling support using sturdy materials such as bricks or stone (do not use wood or cardboard – both will decay over time). A full BioPod™ Plus can be of considerable weight - make sure the foundation is stable and will not shift over time. An elevated unit can be easier to harvest, especially the drainage of liquids.

Starter Bedding Not Required. Unlike worm bins, this is absolutely not necessary for start up or continued operations. Aeration is achieved through the air vent and lid port. It will take more than 1-2 weeks for the system to become self-sustaining – do not be tempted to add bedding or newspaper. If bedding is added, it may retain liquids and obstruct the drainage system, resulting in bad odors. **Do not confuse bedding with a ‘topper’** – the latter is a surface barrier, usually made from long-cut, shredded, moisten office paper – the purpose is to retain moisture in arid environments, while preventing filth flies from laying eggs directly on the food scraps.

Capacity of BioPod™

In order to prevent system overload in your residential unit, keep the quantity of food scraps at or under 5 lbs (2.2 kg) per day.

System Start Up. This is the most gratifying step in the BioPod™ Plus set up process. For the **initial** ‘seeding’ of your new unit, use ordinary kitchen food wastes minus any meat or fish scraps because of the potential to attract unwanted guests. Once the unit is up and running, this issue is no longer relevant, due to the speed of digestion by the grubs. Coffee grounds, starchy foods like stale bread and pasta, and **fermenting corn** are especially useful at attracting pregnant females. Moistened or soak overly dry foods first, before adding to the pod. Spread the scraps out onto the bottom of the pod, and if you purchased grubs separately, go ahead and add them as soon as they arrive. If it is seasonably cool, gently place a piece of moist cardboard on top of the

pile to help retain heat and moisture - making sure there is enough space around the edges for air to reach the pile. You may also use an electric seed starter pad underneath, provided it doesn't overheat the contents. **DO NOT start your unit off with too many food scraps; you must start slow, until your population of BSF begins to rise naturally.** A good rule of thumb on an initial setup is 3" of food scraps. Introducing too many scraps in a new setup *before* you have enough soldier grubs to consume them may result in the system going anaerobic (leading to foul odors). Once your colony is established (no less than 1-2 weeks), feel free to increase the amount of food scraps added to the pile. You will know your system is sustainable when all or most of the scraps are digested daily into a soupy brown mass where most of the original contents are no longer identifiable. Most food waste in an active pod is broken down in 1-2 days.

Collection of Food Scraps. You may have a problem obtaining enough food waste to feed your colony. If possible, collect additional scraps from the office, neighbors or restaurants. Meat and dairy products are acceptable in an established unit. Small soft bones from birds and fish will decompose and digest over time, but it is **not recommended to add mammalian bones, clams or thick chitin shells.** If you store your food scraps in the house or garage before emptying them into the BioPod™ Plus, you will need to keep them aerobic or they will start to stink. A compost pail with a carbon filter is an adequate means of low-odor storage. It keeps out critters and insects, but allows air to get through. If you have more than 1 unit and decide to collect greater quantities of food scraps from your local community, just keep in mind not to let the food sit for any length of time in an enclosed, airtight container, or foul odors may result. Always keep the temporary storage and transport vessel **breathable**, and you should be fine. To minimize fruit or houseflies, cover the food with moist paper towels or wet newspaper – those varieties of flies tend to lay eggs on exposed food scraps, so covering the scraps will help mitigate unwanted maggots. BSF females tend to lay their eggs **adjacent** to food, so the paper should not be an issue. Never add liquids directly to a pod; excess liquid can cause problems if it is not properly drained away. If you have soup or dairy with lots of nutrients that you don't want to discard, use dry foods like stale crackers to soak it up – don't waste food scrap energy – be creative!



FINDING BSF:

1. **NATURALLY**
 - food scraps
 - grub leachate
2. **FRIEND'S POD**
3. **COMPOST PILE**
4. **WORM BIN**
5. **PURCHASE**

Acquisition of BSF. If you have native stock of BSF in your area, chances are they will populate your unit without active intervention. This even happens on patios of multi-story complexes in highly urbanized areas. **Adult females are attracted to imperceptibly low levels of food odors emitted from your pod and will instinctively oviposit (lay) eggs under the protective, convenience cap covering the top ventilation port.** The subtle scent of food scraps also serves as a directional guide to newly hatched larvae. Once a female finds your pod and lays eggs, it usually takes about 1-2 weeks before you notice the juveniles actively digesting the contents.

If you want to *accelerate* the formation of your colony, or you reside in an area where few to no BSF are present, you may inoculate your unit with an egg case or juveniles from an existing pod, compost pile or worm bin. Adult BSF are relatively slow flyers and are easy to capture from an existing compost pile or worm bin (that has food scraps), due to their docility while at rest. Simply net a few adults and place them in the pod, and the females will do the rest. You may also obtain live juveniles or dormant puparium (ready to hatch into adults) from online sources. Whatever the method used to artificially introduce soldier grubs into your system, the results will be the same – quick maturation, and if weather permits, pupation into a breeding population of adults – ready to continue the lifecycle by laying new eggs in your pod. Keep in mind the liquids

mentioned previously **are a strong attractant** – a small quantity from another pod added to your pile will draw in any gravid females from the surrounding vicinity, and stimulate them to lay eggs.

Another simple way of establishing a colony fast is to take some of the egg laying strips from an active unit and place them using Velcro on the inside of the main lid. Such an exchange will not harm the existing colony or eggs. Fresh clusters of BSF eggs are bright white in color, whereas empty casings are brownish. If made from corrugated plastic, clean out and refresh your poly egg strips once a year with a quick soak and rinse in warm water with mild soap. If made from cardboard, simply discard into your compost pile and cut new ones from an old box. Additionally, **'painting' the underside of the lids and/or the corrugated egg strips with the liquid effluent from another pod will entice gravid females to oviposit their eggs.**

Permeable Ground for Natural Drainage. Though it is NOT recommended, for those who forgo capturing the leachate (liquid effluent) using the included drainage system, the pod will need to be placed on a porous surface where the compost effluent can passively drain into the ground below. **NEVER** allow the liquids to pool or stagnate, as this will confuse the gravid females, who may lay eggs in the incorrect location. Suitable surfaces include mulch, pine straw, bark, open soil, sand, grass or gravel. The liquids are harmless to the environment, and will actually provide nutrients to the surrounding plant life. To improve drainage, heavy clay soils can be amended with PermaTill, compost or soil conditioner with added gypsum. Unless you are capturing and diverting all of the BioPod™ Plus liquids using the drainage hardware that comes with your unit, percolation into the ground below must be insured.

The BioPod™ Plus is not a toy. To prevent damage to the unit or possible injury, keep away from unsupervised children or pets.

Collecting the Liquids. The liquid effluent is a powerful female attractant and egg-laying stimulant; if collected, it must be covered so as not to divert the females away from the egg laying section of the pod. This will insure that the gravid female adults continue to lay their eggs on the underside of the lids. If you wish to simply allow the liquids to drain naturally, creation of a shallow pit underneath the drainage port should prevent the females from detecting the liquid, provided the liquid quickly infiltrates the ground. **The liquids contain microbes and can be highly acidic; always wear protective glasses and gloves when handling the leachate.**

KEEP LID ON TIGHT
Because the grubs are negatively phototactic (they naturally shy away from bright light), it is best to keep the lid on at all times when access is not required.

Protecting Your Pod

Pets & Wildlife. Many animals are attracted to the scent of food; the BioPod™ Plus is no exception. Do not place in a dog run, or where wildlife such as raccoons, vermin and bear can access the system. Electronic chasers and chemical deterrents are only marginally effective, and if critters are hungry enough, they will try anything to get into the unit. Bungee cord spiders are quite useful at helping prevent opossums, raccoons and skunks from entering the main chamber; however, they can still access the collection

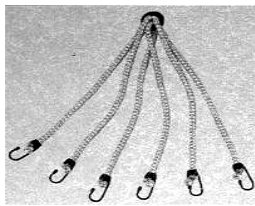

Helps keep out critters

How to Make Homemade Egg Laying Strips
Cut 2" wide and 5" long strips (1" x 4" is fine too) of corrugated cardboard so that the holes are located along the length of the strip, rather than at the ends. This provides the maximum number of exposed crevasses for females to lay the eggs. Consider stacking them 3-5 high using Elmer's glue. Use Velcro to fasten them to the underside of either lid. Coat with grub liquid effluent if available. A large mason jar with fermenting corn, coffee grounds and a few egg strips is an ideal method of obtaining movable egg cases.

bucket and eat your harvest of tasty grubs. Vermin can only get in if they gnaw their way through. The best remedy for rodent control is to capture utilizing a humane trap, and then relocating to a remote area. As long as the flying adult females have guaranteed access, the unit may be placed in a secure structure, like a chain link pen, netted berry patch, or open-air shed, so that the larger animals cannot enter.

Secure from Wind. If you live in an area where storms are frequent, or where the wind regularly exceeds 50 mph in velocity, it is prudent to use a few bricks to help stabilize and weigh down the pod. Another solution is to obtain a few ground pegs and fasten the pod to the ground using short bungee cords, so that the wind cannot tip over your system. Once your BioPod™ Plus has time to accumulate a significant amount of content, it can become quite heavy – feel free to remove the bricks and cords. A wire tether may also be utilized to secure the pod to a fixed structure during storm conditions.

Household Chemicals. Make every possible effort to keep household cleaners, dyes, solvents, or person hygiene products out of the BioPod™ Plus. These are living ecosystems that may be adversely impacted by many of the chemicals found in and around the home. Do not use man made **or** natural insecticides near the unit – these could repel or possibly harm the adult BSF population in the general vicinity. Treat the pod as you would a worm bin or aquarium – you are their guardians and they depend on you for survival! **If you are feeding your grubs pet or farm animal poop, under no circumstances should you give them feces from an animal that has been recently treated for worms, ticks or fleas.**

Operations

Advice on how to maintain your established system

Raising Soldier Grubs. Once mated, BSF adult females lay between 500-900 eggs in their short life span of 5-8 days. Eggs are normally oviposited on the wall of the pod body, the underside of the lid or in corrugated egg strips (optional) where they will remain until the larvae hatch. To insure survival, the females do not lay the eggs directly on the food scraps within the unit. It takes only a few days (approx. 100 hours) for the cream colored eggs to hatch into BSF babies, which then drop or crawl into the active pile below. In ideal conditions, it takes approx. 15-20 days for the juveniles to grow large enough to begin their migration up to ramps and out the chute into the collection bucket. As long as the grubs are actively digesting food, continue to feed the colony. A simple rule of thumb on feeding: monitor digestion rates daily and feed accordingly – only add more scraps the next day if yesterday’s waste is virtually gone. In cooler weather, or if sufficient food is absent for continual growth, maturity may be delayed several months. In overly arid climates, the grubs may be reluctant to crawl up the ramp due to the threat of desiccation. Having a water bottle to mist the active pile will help entice them to exit the active pile.

Once the climate turns cold and the unit goes inactive and dormant, withhold food scraps and divert all kitchen waste to the compost bin. Dormancy may be delayed a few weeks by using an old wool blanket as an insulation cover or one of those electric seed starter pads placed underneath.

Self-Harvesting Soldier Grubs. The pods have been designed with special migration ramps to make collection a breeze by taking advantage of the natural tendency of the mature grubs to self-separate from the feeding area. Unlike vermiculture, this **auto-harvesting mechanism** is so simple, all one has to do is remove the collection bucket and dump the clean, durable prepupae into a container for use elsewhere. Under dry conditions, grubs cannot negotiate an incline greater than 45 degrees, but if the walls of the unit become moist, the larvae can bypass the ramps and crawl straight out of the pod. Consequently the body’s top lip and lids of the pod has been carefully designed to minimize this activity. However with the collection bucket, it is recommended that fresh, slightly moist bedding be placed in the bottom to keep the grubs sedentary. Ideal bedding includes: RICE HULLS, PEAT, COIR, or SAWDUST (made from untreated wood). If you are experiencing grub escape from the main body, (not uncommon in overly humid or tropical areas), we recommend lining the inside of the body along the top rim with the hook side

of Velcro – the grubs have difficulty crossing this barrier and will eventually find the harvest slot and fall through.

BSF POOP:
= Bio-Manure
= Bio-Castings
= Bio-Compost
= Grub Castings

Accumulation of Grub Castings. Over time, you will have a slow build up of BSF castings at the bottom and sides of the BioPod™ Plus. The food to casting volume ratio is approximately 20 to 1. In other words, for every **100 lbs of food scraps that you add to the unit, you receive around 5 lbs of friable BSF castings.** These castings are light in weight, and possess a healthy, soil-like aroma. They may be added to the garden as is, or added to a vermiculture system (worm bin) for additional processing into valuable worm castings (vermicompost). Because of its crumbled, digested nature and high cellulose content, BSF castings are ideal for producing top-quality worm castings quickly, without having to wait months. Please remember that unlike worm bins, **the typical residential grub composter produces only a very small quantity of castings relative to the quantity of food scraps added** – most of the harvest is in the form of biomass (grubs). Grub Compost (which is a combination of castings, skins and undigested composting leftovers) can be fed directly to redworms, for final processing into vermicastings. Instead of waiting until the end of the year to harvest your grub castings, it is recommended that from time to time a portion of the grub castings and undigested residue at the bottom be transferred to a worm bin for bioconversion into worm poop. Use a small blunt, plastic garden claw and shovel - being careful not to scoop out too many of the grubs (grubs will not harm redworms and vice versa).

When grubs are actively engaged in the consumption of waste, the almost frenzied movement can actually be heard, even some distance from the pod. This distinctive noise is indicative of the enormous power of the species. This combined action of eating and churning creates a natural stirring mechanism that keeps the contents well aerated and draining properly. Oxygenation is essential at minimizing the building up of foul, anaerobic odors.

In order to maximize ramp crawl-off, clean the walls (and ramps) of food debris and casting buildup. Removing clumps from the walls reduces the ability of grubs to scale the walls vertically – forcing them to preferentially select the angled migration ramps.

Storage of Soldier Grubs. To prevent them from transforming through metamorphosis into winged adults, store in a cool, dark, dry location with bedding from the collection bucket (an ideal temperature range is 50-62° F). Do NOT let them desiccate or expose to extreme temperatures, excessive moisture or possible predation. DO NOT compress them under heavy materials. DO NOT place them in airtight containers starving them of oxygen. They are still alive, just entering dormancy. Bringing the soldier grubs up to 75-85 degrees F will reactivate their maturation process and allow them to transform into winged adults. If your pod is producing more grubs than you can currently consume, rinse a few cupfuls in a strainer and freeze them for use in the colder months.

If you live in an area that doesn't have a native population of BSF adults, is advisable to set aside approximately 5-15% of the prepupae harvest under protected conditions so that they may be allowed to emerge as adults. This will insure a locally viable population of wild adults that will continue to populate pods in your vicinity. This recommendation is also applicable for greenhouse settings.

Seasonal Performance & Temperature. In the colder regions of the US, the BioPod™ Plus can only be actively processing food year round if the unit is provided with some type of insulation or climate control, and the juveniles are **continually** fed regularly (the breakdown of waste will produce internal heat inside the pod that is necessary to maintain proper conditions). Like with redworms and vermiculture systems, the BioPod™ Plus will only operate if temperatures inside the unit remain well above freezing. Given these functional limitations, if proper temperatures cannot be maintained, we recommended emptying the entire contents of the pod into your compost bin or vermiculture system for final decomposition. These piles will serve as an over winter spot where pupae can remain dormant until spring. If adequate insulation for your pod is provided in the form of a jacket and /or internal foam cover, and the unit is protected from cold winter winds, functional activity may be extended a few additional weeks. Under normal conditions, little to no crawl-off will occur during the colder months, but will resume as the outside temperature warms.

During the hot months and in arid parts of the US, desiccation and excessive heat may become an issue. To keep the pile adequately moist, add a tiny amount of water to your food scraps and let them soak it up. A piece of moist cardboard / wet paper towels placed on top of the pile goes a long way at keeping the moisture and humidity levels within functional parameters. BSF juveniles can withstand relatively higher temperatures, moisture levels, and pH fluctuations when compared to traditional redworms systems. Make every possible effort to keep the internal temperatures below 100-105° degrees F to avoid premature crawl-out. Either lid may be temporarily propped open to allow heat to dissipate. ***Hermetia illucens* is a very hardy species and can temporarily withstand environmental extremes, however, the inside of the pod should be above 55-60°F and below 100-105°F to maintain optimal conditions.**

Accessing the Pod. BSF juveniles do not fancy bright light. Similar to composting redworms, optimum performance is achieved in full shade. Like redworms, they will naturally flee into the depths of the pile when exposed to light, as a means of avoiding possible predation. It is recommended the access to the pod be limited to late afternoon or early morning, so as not to overly stress or disrupt the colony. If you have to open the main lid frequently, a ½” – 1” moist layer or ‘topper’ of shredded office paper will not only help to keep other species of flies suppressed, but will keep the pile dark, humid and cool - even with the lid off. Use any paper material sparingly in your pod – it is not readily digestible.

Drainage and Collecting Compost Leachate. The concentrated liquid effluent may be continually harvested by means of the advanced drainage system, consisting of a drainage pad, drainage plate, liquid catchment reservoir and external plumbing. Once liquid has accumulated in the reservoir, simply open the valve and empty into any receptacle. As long as the lid is on during rainfall events, the liquid catchment reservoir underneath the drainage plate should only be receiving liquids from digestion of the food scraps and condensation - NOT precipitation. Exposure to rain may inadvertently overflow the reservoir and possibly the whole pod - resulting in collapse of the entire colony and foul odors. DO NOT keep the lid open if it is going to rain!

As you harvest the leachate, continually check to make sure the liquids flow. Though clogging is rare, a standard pipe cleaner or aquarium brush can help dislodge any large particulates that may be blocking the drainage system. Do not allow the liquid to sit open; the leachate is a powerful attractant for gravid females and may confuse and misdirect their egg laying. Similar to compost tea, pod effluent is a living liquid, and best when used immediately. Dilute with non-chlorinated

water at room temperature (so as not to harm the beneficial nutrients and microbes) and apply to ornamental plants as a mild fertilizer. A good rule of thumb is to dilute the liquids at a 20:1 ratio. As with all plant fertilizers and soil amendments, use seasonally during the growing period, or year-round with houseplants.

As a precaution, it is advisable to wear latex gloves when handling the leachate or cleaning the filter. Undesirable pathogens may find their way into the pod by contaminated food scraps, and as a result may be present in the effluent. Additionally, do not use the liquid directly on leafy plants intended for direct human consumption (such as lettuce, turnip greens, spinach, celery, etc).

Rainfall. Rain or hail will not affect the performance of the BioPod™ Plus; however, BSF adults are not active during precipitation events, so you may not see any adults flying around until after the stormy conditions dissipate. Never let water pool around the unit if you have your system directly on the ground – always ensure that ample drainage exists for the liquids (if you forgo using the drainage system), as well as natural rainfall. If liquid does appear in the collection bucket due to condensation, simply empty it into the ground or allow it to be absorbed by the replaceable bedding.

Ventilation. The lid is fabricated in such a way that allows a continual flow of air to enter the pod at the harvest slot. The air exits through 1) the vent port covered by the protective, convenience lid as well as 2) the slot in the collection bucket. The drilling of additional holes in the unit body is not necessary or recommended. If the larvae become heat stressed due to higher than normal temperatures, temporarily elevate the lid with a sturdy stick or piece of wood until the heat dissipates. Exposing the colony to the elements by removing the lid entirely is not recommended.

Troubleshooting

Simple solutions to the most common issues and questions

This section is by no mean exhaustive. Please check online for additional information or simply drop our customer service department a quick email. Please allow a reasonable amount of time for our team of experts to analyze your situation.

Are these creatures dangerous in any way?

BSF adults have no mouth parts – therefore they do not feed, nibble on plants or bite in any way. They fly slower than other insects, and resemble dark-colored wasps but do not have stingers. Basically, they are nothing more than a breeder with a very short lifespan. As the mature grubs self-harvest out of the active chamber, they auto-cleanse by emptying their digestive track before entry into the collection bucket.

Do these colonies spread germs that can harm my family?

The flying adults have a very short lifespan; they do not even possess functioning mouth parts necessary to feed. Consequently, they do not harbor germs that may cause and spread disease in humans. They are not like flies or yellow jackets – they will not cause a nuisance at your next picnic. Because they are so efficient at composting wastes, having an active colonies of juveniles actually *inhibits* the growth of insects that do carry germs, like the common housefly. However, as with all garden tools that are outside in the yard, dirt and bacteria collects naturally, so wash your hands with soap and water after handling your pod or any soldier grubs.

Is my system going to stink up a storm?

Established colonies that are actively processing food wastes will not produce noxious odors, so long as they remain aerobic, and the liquids are allowed to drain away. Units that are given too many scraps could overwhelm the colony – do not overfeed. This is doubly true with newly setup systems. Do not add an abundance of liquid wastes like soups or sauces; this may result in pockets of oxygen deficiency, which can lead to stinky smells. Drain off all liquids in your kitchen waste before adding them to the system, unless your pod is exceptionally dry. If your pod gets too ‘soupy’ add in some dry shredded paper or cardboard to sop up the

Units that are given too many scraps could overwhelm the colony – DO NOT overfeed.

excess moisture. This will be broken down along with the kitchen waste. Dried soap-free sponges will also successfully absorb any pooling liquids, and not add permanent bulk to your system. Just remember to wear gloves when removing the saturated sponges. As a preventative measure, check the drainage system for clogging once or twice per month. **Please understand that a functioning pod will emit a unique, trademark odor indicative of BSF (harmless to humans and pets) – this scent smells a little like ripe fruit compost and is created naturally by the juveniles. This odor also helps to deter unwanted arthropods like house and fruit flies from taking up residence in your pod.**

I can't find any BSF in my new setup, only flies – what am I doing wrong?

Most new start-ups that allow BSF to find the pod naturally will invariably attract houseflies *faster* than BSF – they are much more common, and normally more closely associated with humanity. Except on certain farms, BSF adults tend to be *less* common in nature, so it might take more time for them to detect the scent of food scraps and lay eggs in your system. Additionally, the hatching time and life cycle for BSF is a little longer than house and fruit flies, so it can take several weeks to establish, populate and overtake your unit. If you see babies after only a few days, chances are they are house or fruit flies, and not BSF. They may be left there, as the BSF babies will soon dominate the pod, displacing the undesirable fly species that may have taken up residence in your pod. If tiny, fast-wriggling larvae begin appearing in the collection bucket only a few days after setup, chances are they are house or blow fly larvae. To prevent a house fly infestation in your area, take these tiny larvae before they have a chance to pupate and bury them deep somewhere in the garden. Better yet, feed them to your fish or chickens!

Most localities in the US (hardiness zone 6 and higher) should have native BSF adults present; however coverage is only assumed, not guaranteed. Should you not wish to wait for your colony to develop naturally (2-3 weeks), we have growers that will ship you BSF year round. Coverage in zone 6 is sporadic; most parts of zone 7 should have viable populations.

Common houseflies tend to lay their eggs *directly on food wastes*, unlike BSF which lay them some distance away (such as on the underside of the protective cap). A great way to **mitigate the presence of regular house and fruit flies** and their babies is to take a piece of dampened cardboard and cover the pile of food waste – this will prevent many of the unwanted flies from accessing the scrap and reproducing via eggs laying– just make certain the cardboard layer is not air tight, or you can cause the system to go anaerobic. You may also use a ½” to 1” topper of shredded moistened, long-cut office paper – this will accomplish the same goal as the cardboard, but without the need for a peripheral gap. Since paper and cardboard is not normally eaten by BSF grubs, *use in moderation*. As a rule of thumb, the pod has been properly seeded with BSF when house and fruit flies are no longer present.

Will my BioPod™ Plus attract unwanted guests?

The scent of food has the potential for attracting a multitude of hungry creatures; always keep the lid on (especially at night) and do not place in areas where the unit is susceptible to access or damage by pets, wildlife or curious children. Raccoons are notorious for raiding compost bins – consider fastening the lid and bucket with some bungee cords, as these seem to confuse them.

Why does it appear that some foods are being ignored?

Some foods will not be completely broken down by the active juveniles but will be decomposed in the lower compost levels by beneficial bacteria and fungi. Animal bones, like those from pigs or cows, are too hard to be digested by either the BSF juveniles or the biologically rich compost; it is best to refrain from placing these inside the units, unless you don't mind having them mixed in with your casting residue. Avoid adding the following foods: thick chitin exoskeletons (ex. lobster), bivalve shells (ex. clams), mammalian bones (ex. T-bones), avocado peels, citrus rinds, and coconut husks. Eggshells will decompose slower than most other foods.

Can I use my system indoors?

These units are not currently designed for indoor use, though some researchers are successfully rearing BSF in greenhouse settings. Wild BSF adults do not have access to the inside of buildings, and it will be difficult to maintain a prolonged colony without fresh eggs or babies. Near the end of the fall when the weather starts to get cold, you can move the pod into a sheltered area like a garage, greenhouse or shed for extended harvesting.

Why can't I use my BioPod™ Plus year round?

You can do this in the southern states and along the western coast, as long as the temperature inside the unit remains well above freezing. To do this, provide an insulation cover directly on top of the inside contents of the active pile, making certain to leave a loose gap around the perimeter, so that the system receives enough oxygen, and does not retain (or lose) too much heat. Additionally, a wool or thermal blanket could be used to cover the entire unit on exceptionally cold nights. The warmth to maintain a hospitable climate inside is generated internally by the active juveniles – **do not stop feeding them** or the temperature could plummet and the whole colony may collapse and go dormant. The major issue with winter operation: providing the system with a consistent supply of ample food. Keep in mind that little to no crawl-off will occur during the colder periods.

I don't have any shade, what can I do?

Full shade is required for the system to operate correctly. Units placed in direct sunlight will heat up too much, resulting in early crawl-off of premature adults (lighter in color) and may even cause the entire colony to collapse. Even in full-shade conditions, temperatures over 100-105° degrees will cause premature crawl-off. The best solution is to purchase an inexpensive shade canopy or trellis that protects the entire colony from the heat of the sun. During extended heat waves, do whatever is possible to keep the temperature below triple digits (ice in sealed bags, cold packs etc.).

I am going on vacation, will my pod be ok?

As long as your pod is free from predation, curious children, and extreme weather, your system should operate smoothly while you are away. In nature, there is rarely a steady stream of food for any species, so the intermittency of scraps will not be an issue. As long as you have been feeding your colony on a regular basis, the grubs can survive for 1-2 weeks without being fed (provided it is not too cold). To allay your concerns, feel free to add in some additional scraps the day before your departure, or if you have a friend checking in on your place, have them throw in some scraps for good measure. **If it is exceedingly cold outside**, we do not recommend withholding food

for more than a day or two – the continual digestion is what keeps the inside warm and hospitable – if you stop feeding them the temperature in the pod could plummet.

Ants are hauling off my BSF eggs and babies, how do I control them?

Ants are notorious invaders of compost and worm bins. In most pods, ants don't seem to bother the older grubs in an active pile - only the food scraps, eggs, collection bucket grubs and newly hatched BSF babies. Nonetheless, there are several means of control that will not involve poison sprays or toxic pellets. The first is a barrier paste called **Tac-Gel** that the ants simply will not cross. We have found it to be an effective means at preventing ants from entering the units. Make certain that the application completely encircles the unit. If you have it elevated on a table or stand, then apply barrier paste to each leg. It is recommended that the user wear latex gloves while handling Tac-Gel. Please realize that if you have any shrubbery or garden tools touching the unit, ants will use that as a bridge and invade the pod. So keep debris free and clear of the pod at all times. A second, more natural means of control would be a circle of **diatomaceous earth** (DE) on the ground surrounding the system. This powder is the skeletal remains of microscopic phytoplankton, and is composed primarily of silica. The DE causes openings at the seams of the ant's chitin exoskeletons resulting in water evaporation and desiccation. Repeat applications are necessary to maintain effectiveness, especially after a rain event. The third means of control would be some form of **liquid barrier** that could take the form of a shallow moat of water or mineral oil (evaporates much slower). Used coffee cans at each table leg are quite effective. Keep in mind that mosquitoes may become an issue in stagnant or pooling bodies of water.

I am getting immature larvae in my collection bucket. What do I do?

When the BioPod™ Plus system heats up to much, larvae that are not yet ready to pupate will vacate the unit, in an effort to find a cooler location. On very hot days, you might see an accumulation of cream-colored, multi-sized grubs in your bucket, instead of the normal charcoal grey-black ones. As soon as the temperature drops, simply dump the entire contents of the bucket back into the pod. If it is not too much trouble, feel free to separate out the black pupae, but it is perfect fine to add them all back into the pile – they will simply crawl out again if they have finished feeding.

Grubs are crawling all over the interior of the collection bucket, what do I do?

If they are crawling up the sides, chances are there is too much moisture inside the collection bucket. Add a handful of dried peat or coir and that will absorb the excess condensation so that the pupae will be too dry to climb the sides. This bedding will also settle them down considerably, and provide perceived refuge. The new collection bucket has been designed in a way that diverts the majority of excess condensation away from the inside by means of a small channel surrounding to top opening.

Can the pod be used for pet waste disposal?

Soldier grubs love feces and will devour them as fast as food scraps. However, the residential BioPod™ Plus was designed to digest kitchen leftovers, not pet waste, nor a combination of the two. The main reason we do not recommend adding pet waste into a functioning system is the pathogen issue. The germs that are associated with feces are a mixture of good and bad bacteria

& viruses – we do not want our users to introduce those into a biological system that produces a finished product that may be used in a vegetable garden (the compost or castings) or fed to domesticated animals (the grubs) that might then be used for food or egg production. Though cross-contamination and transmission between species is unlikely, it is best to recycle all pet poop in a system designed exclusively for that purpose. But will they eat manures? The answer is YES.

I don't have a yard, can I still use the BioPod™ Plus?

Yes. As long as you have a heavily shaded area of your property, you can still use a BioPod™ Plus without the need for an actual yard. The residential pod has already been tested in multi-story buildings in US cities, and will work with a little extra monitoring and care. It will still be necessary to situate the unit in an area that is completely or partially outdoors, such as a patio, porch, balcony or lanai. Indoor locations are not feasible, unless the flying adults have full access through a window or door, since the wild population of females still need to find the unit and lay eggs. Like with yard-based systems, you must insure that the unit is placed in full shade so that the inside is not allowed to heat up above tolerable limits (around 100-105° F). Radiant heat from concrete and building materials may indirectly increase the temperature of your balcony – be vigilant about extreme fluctuations in temperature. Keep in mind that the liquid effluent (the compost leachate) is continually produced as a byproduct of digested food scraps and must be collected by the integrated drainage system – don't let it pool on your patio. This liquid is a powerful attractant for the females, and we don't want it pooling anywhere inappropriate because that might confuse the gravid females on where to lay eggs.

I don't see any grub in my unit, how do I attract females to my pod?

Along with fresh food scraps, the liquid effluent from an existing pod may be used to attract gravid females to your system. Simply 'paint' the liquid on the underside of the lids and /or homemade egg laying strips, and nature will do the rest. Fermenting corn mixed with some coffee grounds can be placed in a tall mason jar near the pod – this will additionally help attract females searching for egg laying sites. You can have some egg laying strips attached (with Velcro) to the inside of the jar – when you see egg cases filling up the holes, move the strips to the pod's interior for hatching. Use protective gloves when handling the effluent.

I don't have use for so many grubs – what the heck do I do with all of them?

Most people set up the pod for the specific purpose of grub growing. Some feed the grubs to their chickens, bullfrogs, koi ponds, tilapia or pet iguanas. Some freeze the grub for use at a later date. Individuals can save an average of \$40 bucks a month by not having to buy live food at the pet store. Anglers use them as free bait instead of purchasing expensive earthworms. A growing number of users are becoming familiar with the benefits BSF grubs bring to the migratory songbird habitats that are springing up in people's backyards. Along with supplying birdbaths and breeding shelters, it is recommended that carnivorous and omnivorous birds be fed a balanced diet including calcium-rich soldier grubs. Any feeder unit intended for mealworms will suffice as a suitable dispenser of grubs. Your birds will thank you in song! As a last resort, you can always give them away as gifts (we are not kidding) or simply allow the grubs to hatch into adults, thus repopulating the native stock in your area. If you are interested in helping to re-establish the local population of BSF, take the bedding and grubs out of the collection bucket and place in a shallow

bin. Protect the bin from rain, sun, and predation. In a few short weeks, you will have newly **emerged adults ready and willing to process wastes in your area.**

I am a really busy person. How much time do I need to put aside for one of these?

Well, the initial setup up is really the most time-intensive part of the whole process – and that only takes a few minutes. To get this unit up in running, you will need to put aside one daylight hour, preferably when distractions can be minimized so that you can focus on reading this manual. Surprisingly, once the pod is setup, there is not much additional work, other than feeding, harvesting, liquid collection and monitoring – that can add up to approx. 15-30 min per week. Since the liquid effluent and active pile are replete with beneficial microbes, always wear latex gloves when handling. Since the grubs will auto-separate using the sloped migration ramps, there is no additional time or effort spent on collecting the grubs from the active pile. If you live in an area that doesn't allow year-round operations, you will have to spend some time (approx. 1-2 hours) cleaning and dismantling the unit, so that it can be put away into seasonal storage during the coldest months. As soon as temperatures turn cold, we recommend dumping the entire contents into your compost bin for overwintering of grubs as well as final breakdown of the BSF residue.

How can I keep my unit from overheating?

Depending on your climate zone, you may experience summer temperatures that exceed the tolerable limits of a functioning BioPod™ Plus. In order to prevent premature crawl of immature larvae, you must decrease the internal temperature of the pod. Freezing food scraps before adding them will help bring the thermal levels down, as well as burst open plant cell walls, exposing more nutrients to the grubs. Another nifty trick is to use frozen, reusable ice packs. We do not recommend using liquid gel packs as these could fail, and depending on contents may poison the inhabitants of your colony. Find ice packs that have a tough, thick shell and resist abrasion. Use several, and switch them out after they have thawed. Raw ice can introduce too much moisture to a system, so we don't suggest adding it to your colony directly. Use raw ice only if you can keep it separate in a container that will not leak, puncture or spill. As long as there is no chance of rain, temporary removal of the lid will also help to lower the internal temperature.

Grubs are escaping from my pod! What can I do?

In overly humid areas, which is common in parts of Florida and Hawaii, there may be enough moisture in the pod to allow grubs to scale the inside walls and squeeze out of tiny openings between the lid and body. Normally, this less-than-perfect seal is ideal for helping keep the pods oxygenated, but may have the unfortunate side effect of letting grubs out of the active pile. If you find escapees, return them to the pod to complete their growth cycle. While units from May 2011 onward have an added lip to the top of the body (minimizing escape), older units can benefit by a circle of Velcro surrounding the inside of the body (near the top). Use the loop side of the Velcro strips.

Self-Help Matrix

PROBLEM

SOLUTION

Unpleasant odors are coming from the pod	Your system has gone anaerobic. Ensure drainage system is not blocked. Mix in some drier food scraps to absorb excess liquid and break up any pockets of stagnant air with a compost turner or garden tool. BSF colonies do emit a unique, trademark odor that is neither harmful nor offensive, but its distinctiveness is noticeable by most users.
I have housefly and fruit fly larvae in my pod	New setups can get infested with these maggots initially; this is natural. Over the course of the next few weeks, they will be displaced by BSF larvae, which have a longer life cycle.
No BSF larvae	BSF adults may not be present in your general vicinity. Order some pupae online to get your system started, or gather some larvae or pupae from a friend's pod or compost pile.
Dead larvae in the pod	Toxic poisons such as those found in some medications or household cleaners may kill your juveniles. Extreme temperatures can also harm your colony. Keep out questionable chemicals and protect from severe temperatures. Never use manure from animals recently treated for worms.
Not all food is digesting fast	Some foods like citrus rinds or the thick chitin shells of crabs will take longer to digest in your pod, if at all. It is necessary for beneficial fungi and bacteria to first neutralize acids and break down chitin shells before the grubs can devour them. Grind up large fish and poultry bones as much as possible before placing them in the pod to insure decomposition and processing.
My unit is heating up too much	Simply crack or remove the lid and let some of the heat escape, or throw some frozen ice packs in the unit. Freeze some recent kitchen scraps before adding them. Just make sure to replace the lid should it begin to rain!
Adult females are laying their eggs in other places	Make sure that the liquid effluent does not openly pool but drains completely into a receptacle or directly into the ground. Females have extremely sensitive olfactory reception and will lay eggs anywhere they detect the scent of grub leachate.
My unit seems too dry	In hot arid regions of the US, the pod can dry out too much. Replenish the moisture by simply adding some de-chlorinated water to your food waste a few hours before dumping in the pod (the scraps will swell with absorbed water). Generously misting the contents with a spray bottle will also alleviate some of the dryness. Warning: NEVER pour water directly into your unit!
The sight of an active BioPod™ makes me sick to my stomach.	It is normal to have the entire pile moving and wriggling – you can actually hear them eating from several feet away. A soothing chamomile tea or back massage will help calm your nerves. Just keep reminding yourself that all stages of the BSF are completely harmless, and will not transmit disease.
There are small cream colored juveniles in the	Heat stress causes early crawl-off. During heat waves or when the pod exceeds 100 degrees, you may find younger, lighter colored soldier grubs in the collection bucket trying to escape the heat.

collection bucket

Simply separate and place them back in the unit so that they may continue to grow. For convenience purposes, you don't even have to separate the two kinds; simply throw the whole batch back in and the mature ones will crawl out again.

For the Kids

Projects for the Whole Family

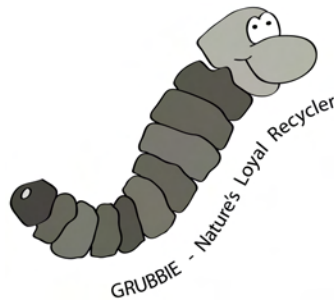

Project 1

How Nature Decomposes Food

Save a mixture of some interesting food scraps in a compost pail next time you want to show the kids what actually happens inside the pod. Have them write down the initial contents of the pail, and record the time of feeding. Then, every two hours, open the pod and check to see what is happening to the most recently added scraps. Have them create a time sheet and log the changes that occur. Which foods were digested the fastest, which the slowest? How many hours before certain scraps were no longer recognizable? Did any scraps survive after 24 hours? After 36 hours? Why? How do the grubbies react when exposed to light?

Project 2

Identification of Various Lifecycle Stages.

Upon close inspection, most ages of BSF can be found in and around the pod. The adults look like blue-black mud wasps, and depending on the variety in your region, may either fly noticeably slow, or dart erratically about. Which strain is present in your vicinity? The egg cases can be found on the underside of the lids. Some may be clinging to the homemade protective egg strips; others may be on the inner surface of the body. Use a magnifying glass to locate some of the egg masses (only a few millimeters across and white / cream in color). Individual eggs are extremely small and difficult to identify. Where were most of the egg clusters found? Approx. how many eggs are found in the clusters identified? BSF babies are difficult to find; they appear as tiny specs of moving flour— it is not until they start feeding that they begin increasing in size. The juveniles have 5-6 distinct growth stages referred to as instars. Each stage transitioned to the next by molting of the chitin skin. Can you identify the various stages of juveniles in your pod? Can you find examples of the mature grubs and puparium in the collection bucket? Have you discovered shed exoskeletons in your bucket bedding?

Project 3

Hatching and Releasing Adults.

Take about two dozen of the dark colored pupae that have recently crawled off and place them in an open bowl with a handful of peat, coir or sawdust. Select ones that are no longer wriggling about. If the bedding material is a noticeably different color it will be easier to see the pupae. Record when these were allowed to go dormant, and how many were added to the bowl. Protect from sunlight, weather extremes and predation. Each day, count to see how many pupae hatched into adults. You won't have any adults emerge in the first few days, but pupation does depend on a number of factors like season and temperature. Compare the daily records and determine the average number of days for your region. If you are fortunate enough to witness an adult coming out of a puparium, watch to see how the wings unfold and slowly expand to normal size.

Project 4

How BioGrubs and Redworms Work Together

After a few months of continuous operation, grub castings will start to accumulate at the bottom of the pod. What remains inside the pod is a combination of castings, exoskeletons and indigestible, composted scraps. The texture is loose and friable, and the color is dark. This material makes an excellent food for redworms. Scoop as much of the castings out of the pod as possible – you might need to dump the surface contents into a temporary bucket in order to uncover them. It is perfectly acceptable to have juveniles and partially digested scraps mixed into the castings – all are compatible with redworms, and will not harm each other. Mix it with some shredded paper and in a few weeks you will have a ready-to-use supply of worm castings. What are the differences and/or similarities between worm castings and grub castings? Take 9 tomato, pepper or eggplants. Add a few scoops of finished worm castings to 3 of them, add BSF castings to 3 of the others, and leave the other 3 plants as the control. Watch and record the growth differences over time.

Glossary

Definitions to key words and concepts

BioPod™ Plus– the name for the unit which houses the BSF colony

Bioconversion – is the conversion of organic materials, such as plant or animal waste, into usable products by biological processes or agents. The BioPod™ Plus is a bioconversion unit.

Black Soldier Fly – the signature, beneficial arthropod utilized in the BioPod™ Plus. Its scientific name is *Hermetia illucens* and the adults resemble through phenotypic mimicry the mud wasp. It is found worldwide in all temperate zones.

BSF – the acronym for Black Soldier Fly

Castings – this is the compost at the bottom of the BioPod™ Plus unit that may be used directly as a soil amendment, or as a precursor for production of vermi-castings, made by redworms. Also called Bio-Castings, Grub Castings, BioCompost or BioManure

Compost Leachate –the nutritious, biologically active, liquid effluent that is the by-product of digestion of food scraps in the pod. The primary component of most household food scraps is water, which collects at the bottom of the unit. In order to maintain aerobic conditions, this liquid must be allowed to drain continually. This leachate is a strong attractant to pregnant females - do not allow the liquids to pool in areas outside the pod.

Clay – soils that have a preponderance of fine particles making them almost dough like in texture. They act as a barrier to water, and can prove detrimental to proper drainage. Use soil conditioner, compost or gypsum to amend heavy clay soils and improve porosity.

Gravid – is a term used in entomology to describe a mated female insect that is carrying fertilized eggs

Grubs – the self-harvesting, auto-separating prepupae that accumulate in the collection bucket. They are an ideal bait, fish food, or bird feed - and may also be fed to livestock or pet reptiles. They may also be used to inoculate compost bins that accept food scraps, in order to speed up the process. These are juvenile form of the black soldier fly, before metamorphosis occurs.

Larvae – the juvenile form of the BSF. These are what hatch out of the eggs and are the main recyclers in the pod

Oviposit – the act of laying eggs by gravid, adult females

Metamorphosis – the transition from juvenile to adult form. This process is analogous to the development of a butterfly from a caterpillar.

Prepupae – the mature grub, normally charcoal grey in color

Prota™ Culture – the process by which a significant portion of the proteins and lipids in a food waste stream are captured and recycled, rather than degraded, into usable biomass by a beneficial decomposer.

Pupae – the dormant lifecycle phase before the grub becomes a flying adult

Puparium – the pupae enclosed in its hardened, chitin skin

Redworms – the most common segmented annelid used in worm bins. Also called red wrigglers or composting worms. They relish castings and residues from black soldier fly bioconversion units and will readily transform these into valuable worm castings.

Soldier Grubs – the grub of the Black Soldier Fly (see Grub)

Vermiculture – the rearing of segmented annelids, specifically composting redworms, for beneficial end products including, castings, leachate, and worms.

Vermicastings – the finely ground finish material in a worm bin (also called worm castings)

Vermi-Compost – this is another name for the worm castings, or worm poop.

Acknowledgements

We would like to thank the following for their contributions

Dr. Craig & Sheila Sheppard

Dudley Pinnock

Gina Fioretti

Grant Canary

Dr. Jeff Tomberlin

Dr. Paul Olivier

Susan Quinby-Honer

Dr. Tran Tan Viet

Jerry Walper

David Pennington

Dr. John and Margie Haley

Bruce Deuley

Dr. Bonnie Jacobs

John Musser

Chapter 10

How to Contact Us

There are a multitude of ways you can reach us listed below

Prota™ Culture

PO Box 660675 #15135
Dallas, TX 75266-0675
Toll Free Sales: 877-444-0450
Customer Service – 214-509-6000
M-F 10 am – 4 pm C.S.T.

Corporate Office

2650 Cedar Springs Road #2226
Dallas, TX 75201
Main Phone: 214-509-6000
Facsimile: 214-279-0445
cs@thebiopod.com

Regional Offices

755 Darius Pearce Road
Youngsville NC 27587
Main Phone: 214-509-6000
Fax: 214-279-0445
cs@thebiopod.com

Internet / World Wide Web

<http://www.TheBioPod.com> - information & support
<http://www.CompostMania.com> - ordering & sales
<http://esrint.com> - history
<http://www.ProtaCulture.com> - background